

WORLD AREA & AMP

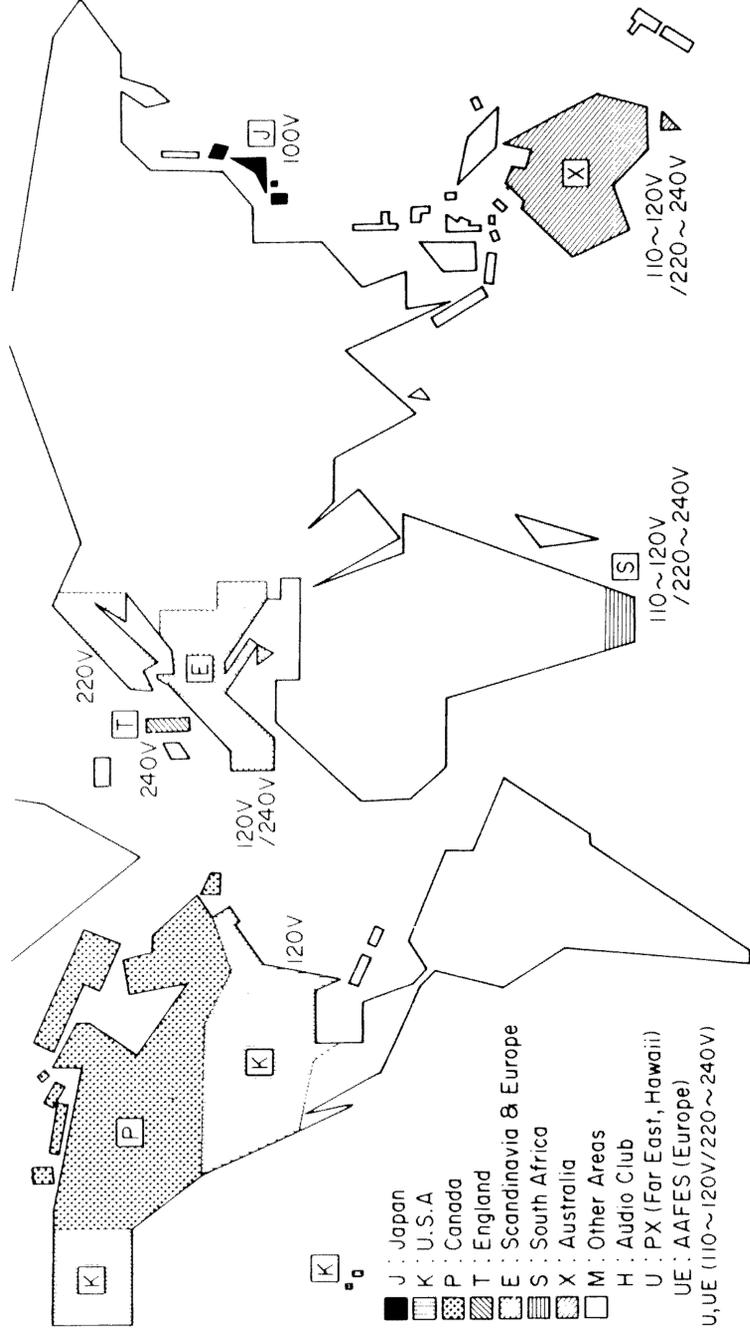

Note:

Component and circuitry are subject to modification to insure best operation under differing local conditions. This manual is based on the U.S. (K) standard, and provides information on regional circuit modification through use of alternate schematic diagrams, and information on regional component variations through use of parts list.

TRIO-KENWOOD CORPORATION

Shionogi, Shibuya Building, 17-5, 2-chome Shibuya, Shibuya-ku, Tokyo 150, Japan
KENWOOD ELECTRONICS
 DIVISION OF KENWOOD U.S.A. CORPORATION
 1315 E. Watsoncenter Rd., Carson, California 90745, U.S.A.
 75 Seaview Drive, Secaucus, New Jersey 07094, U.S.A.
TRIO-KENWOOD CANADA INC.
 1070 Jayson Court, Mississauga, Ontario, Canada L4W 2V5
TRIO-KENWOOD ELECTRONICS, N.V.
 Leuvensteenweg 504 B-1930 Zaventem, Belgium
TRIO-KENWOOD ELECTRONICS GmbH
 Rembrucker Str. 15, 60556 Heusenstamm, West Germany
TRIO-KENWOOD FRANCE S.A.
 5, Boulevard Ney, 75018 Paris, France
TRIO-KENWOOD (AUSTRALIA) PTY. LTD. (INCORPORATED IN N.S.W.)
 4E Woodcock Place, Lane Cove, N.S.W. 2066, Australia
KENWOOD & LEE ELECTRONICS, LTD.
 Wang Kee Building, 5th Floor, 34-37, Connaught Road, Central, Hong Kong

A-76

KENWOOD

COMPUTER CONTROLLED STEREO INTEGRATED AMPLIFIER

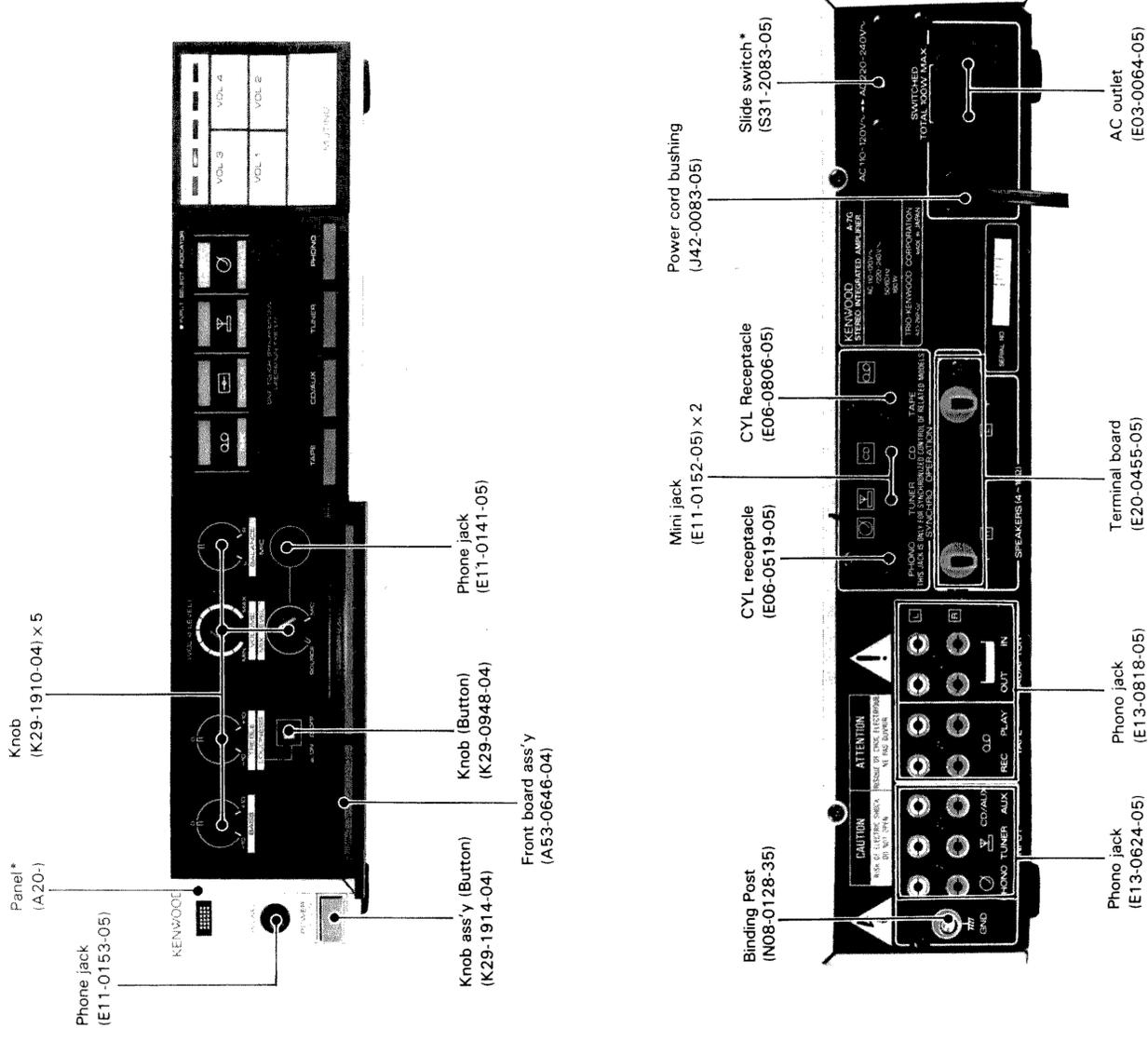

SERVICE MANUAL

DISASSEMBLY FOR REPAIR

1. PC boards behind the power transformer are fixed from the bottom to each mounting hardware with 1 screw. Remove the screw and slide the pc board so that the mounting hardware is released from the hook of the chassis and pull up as shown by the arrow (1, 2).
2. Power transistors may be removed from the heat sink with either a screwdriver or the hexagon wrench (3, 3').

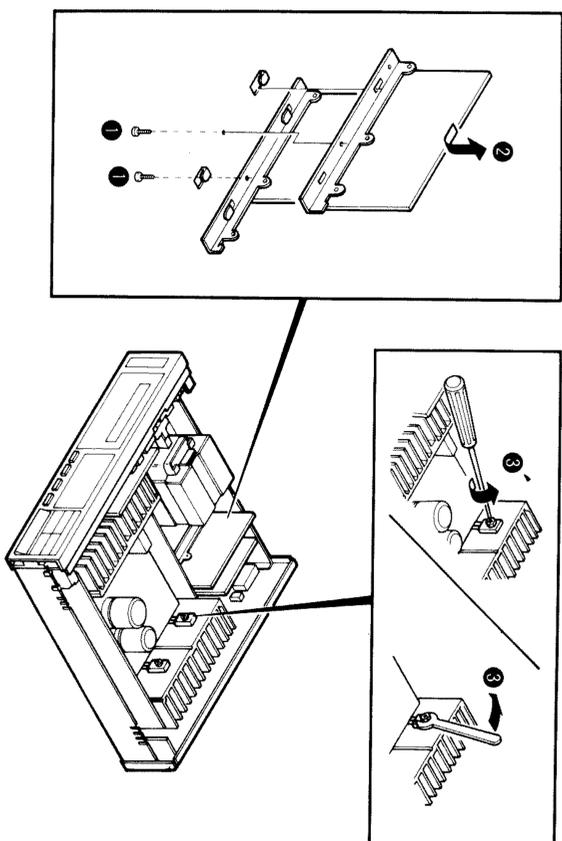

BLOCK DIAGRAM

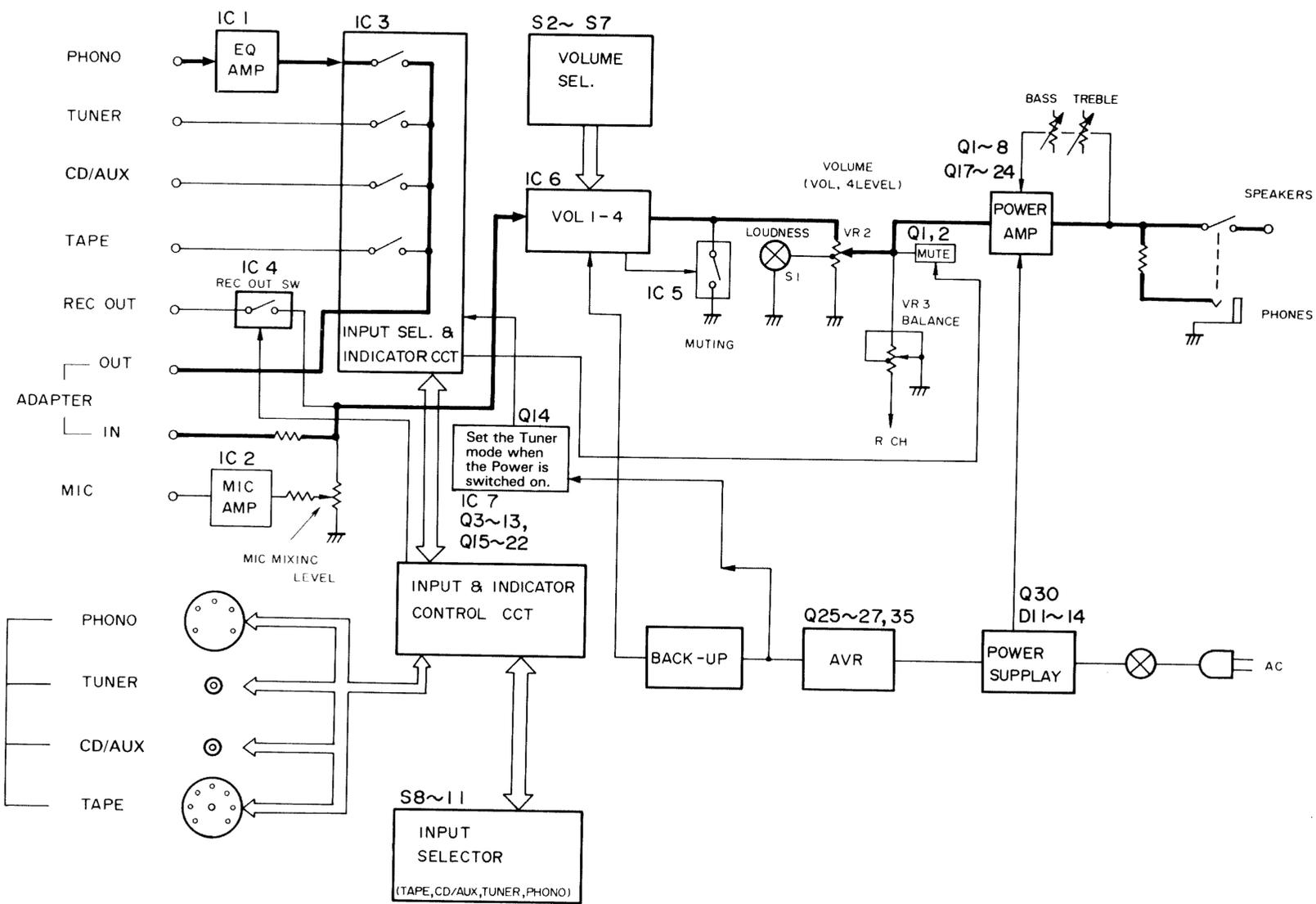

CIRCUIT DESCRIPTION

1. DESCRIPTION OF ELEMENTS

Control unit (X11-2060-01)

Element	Use & Functions	Operation, conditions & interchangeability
Q1, Q2	MUTING (Synchro REC circuit)	
Q3	PHONO switch (Synchro REC circuit)	
Q4	Permission of UP/DOWN signal from PHONO (Synchro REC circuit)	
Q5	CD/AUX switch (Synchro REC circuit)	
Q6	Not used.	
Q7	Inhibit of air check signal (Synchro REC circuit)	
Q8	TUNER switch (Synchro REC circuit)	
Q10		
Q11	Inhibit of selector switching signal during REC (Selector switch input circuit)	
Q12	M-DUBBING switch (Selector switch input circuit)	
Q14	Reset	
Q15	Tuner select switch (Selector switch input circuit)	
Q16	REC OUT forcing switch during M-DUBBING (Selector switch input circuit)	
Q17	CD/AUX switch (Selector switch input circuit)	
Q18	TAPE switch (Selector switch input circuit)	
Q19	PHONO switch (Selector switch input circuit)	
Q20	TUNER switch (Selector switch input circuit)	
IC1	EQ amp	
IC2	MIC amp	
IC3	Input selector switch	Controlled, via IC7, by the amp INPUT SELECTOR and synchro operation.
IC4	REC OUT analog switch during M-DUBBING	During M-DUBBING, turns on by Q12 and Q16 for REC OUT.
IC5	Analog switch for muting	Controlled by the IC6 TM and TM_{ctrl} .
IC6	VOL. 4 LEVEL muting switch	Controlled by S2 to S7.
IC7	Selector switching inverter	Turns ON/OFF by the INPUT SELECTOR and synchro operation and controls IC3.

Main amp unit (X07-2120-11)

Element	Use & Functions	Operation, conditions & interchangeability
Q1-Q4	1st stage differential amp	
Q5-Q8	2nd stage differential amp	
Q17-Q20	Driver	
Q21-Q24	Power transistor	
Q25	AVR	
Q26	AVR	
Q27, Q35	Shock noise prevention	
Q30	AVR	
Q33, Q34	Bias	

CIRCUIT DESCRIPTION

2. IC3/IC6 (LC7815H) TERMINAL FUNCTIONS

Terminal name	Terminal No.	Input/output system	Description																									
V_{ap}	28		Power terminal (+) (-) 2 power supplies $V_{ss} = GND$ $V_{EE} = (-) V$																									
V_{ss}	9																											
V_{EE}	20																											
A_{in} , B_{in} , C_{in} , D_{in}	2, 3, 4, 5		<ul style="list-style-type: none"> Input terminals assigned to switching analog switches ON. Priority when pressed simultaneously: $A_{in} > B_{in} > C_{in} > D_{in}$ Pulse noise operation error prevention. (Discriminates pulse widths by the mute/delay time.) 																									
A_{out} , B_{out} , C_{out} , D_{out}	27, 26, 25, 26		<ul style="list-style-type: none"> ON-state indicator LED driver outputs corresponding to the analog switches. N channel open drain. (Source is connected to V_{EE}.) 																									
A_1 , B_1 , C_1 , D_1	10, 11, 12, 13		<ul style="list-style-type: none"> A - D : Audio signal input terminals. COM : Audio signal output terminals. Signal inputs (A - D) are switches on by the assigned inputs ($A_{in} - D_{in}$) as shown in the table below. <table border="1" style="margin-left: 20px;"> <thead> <tr> <th>Assigned inputs</th> <th>A_{in}</th> <th>B_{in}</th> <th>C_{in}</th> <th>D_{in}</th> </tr> </thead> <tbody> <tr> <td>A_{in}</td> <td>1</td> <td>0</td> <td>0</td> <td>0</td> </tr> <tr> <td>B_{in}</td> <td>*</td> <td>1</td> <td>0</td> <td>0</td> </tr> <tr> <td>C_{in}</td> <td>*</td> <td>*</td> <td>1</td> <td>0</td> </tr> <tr> <td>D_{in}</td> <td>*</td> <td>*</td> <td>*</td> <td>1</td> </tr> </tbody> </table> <p>* Don't care.</p>	Assigned inputs	A_{in}	B_{in}	C_{in}	D_{in}	A_{in}	1	0	0	0	B_{in}	*	1	0	0	C_{in}	*	*	1	0	D_{in}	*	*	*	1
Assigned inputs	A_{in}	B_{in}	C_{in}	D_{in}																								
A_{in}	1	0	0	0																								
B_{in}	*	1	0	0																								
C_{in}	*	*	1	0																								
D_{in}	*	*	*	1																								
TM in	6		<ul style="list-style-type: none"> Input terminal assigned for muting ON/OFF. Detects the rise of input signal and inverts to OFF when muting is ON and to ON when muting is OFF. 																									
TM_{ctrl}	22		No connection.																									
TM out	23		No connection.																									
MUTE in	8		<ul style="list-style-type: none"> Input terminal for forced external triggering of audio muting control signal (MUTE). When it is fixed at "L" level, the MUTE output is "H". Output is "H" when the power is switched ON and "L" otherwise. 																									
MUTE	21		<ul style="list-style-type: none"> Audio muting control signal output terminal. When functions are switched or when there is MUTE IN input, this outputs the pulse determined by the time constant connected with the CR terminal. 																									
CR	1		<ul style="list-style-type: none"> CR time constant terminal for determining the time length of the audio muting control signal. The time difference between the rise of muting signal and the switching timing of analog switch, the mute delay, is determined by C and R3 when TR is ON. 																									
RESET	7		<ul style="list-style-type: none"> Input terminal for switching all analog switches OFF or resetting the muting flip-flop. (Active with "L") 																									

CIRCUIT DESCRIPTION

CIRCUIT DESCRIPTION

3. IC4 AND IC5 (IC4066BH)

Terminal disposition

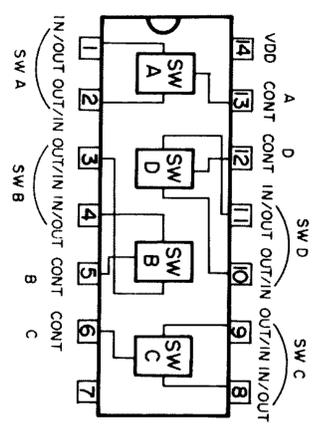

Equivalent circuit

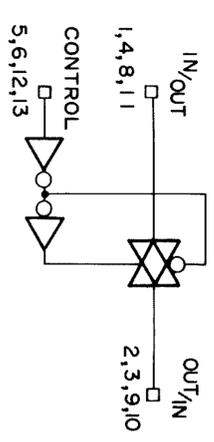

4. RESET CIRCUIT AND TUNER SELECT CIRCUIT

Reset circuit (Fig. 1)

When power is switched ON, C64 is charged via R74, the potential at point A which is split by R74 and R76 changes from 0 to 1.1 V, and IC3 is reset for entering the input select standby condition. When power is switched OFF, the charge of C64 is discharged via R75 and D33. This is necessary because the next resetting would not be possible if it were not discharged to 0 V.

Tuner Select circuit (Fig. 2)

When power is switched ON, the base of Q14 is 0 V. With the ON state it charges C62 via R47. When the voltage at point B has changed from 0 to 10.4 V, Q14 turns OFF and when the emitter voltage at this period varies from 0 V → 11 V → 0 V, one pulse is generated. This pulse is applied to IC3 in input select standby mode so that "Tuner" is selected when power is switched ON.

When power is switched OFF, the charge at C62 is discharged to point A via D34, and the voltage at point B returns to 0 V.

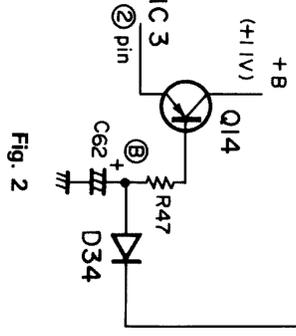
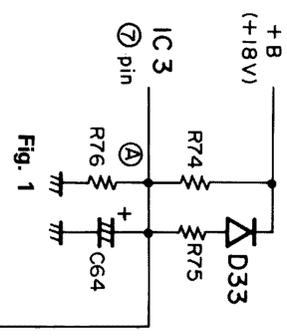

5. "EASY OPERATION" DESCRIPTION

5-1 Input line

Conn.	Pin No.	Name	Condition for turning signal "H"	System operation	Ref. No. on timing chart
PHONO SYNC.	1	Phono sel.	1 pulse from the tonearm is lifted back by operation of the turntable PLAY/CUT, DUBBING or CUEING key.	When the Rec Mute (DECK SYNC, pin 2) is "L", switches the selector to "Phono" and Play/Cut (PHONO SYNC, pin 4) to "H".	6-3~4
	2	Dubbing	1 pulse after a moment from when the tonearm is lifted down by pressing the turntable DUBBING key.	Dubbing (PHONO SYNC, pin 2) is output, as it is, to Rec (DECK SYNC, pin 5).	6-4
TUNER SYNC.	3	Up/Down	While a record is played with the tonearm lifted down.	With the selector set to "Phono" and when Green (DECK SYNC, pin 1) or Red (DECK SYNC, pin 3) is "H", the input is output, as it is, to Up/Down (DECK SYNC, pin 6).	6-3
	2	Air Check	While the tuner AIR CHECK key is depressed.	With the selector set to "Tuner" and when Green (DECK SYNC, pin 1) or Red (DECK SYNC, pin 3) is "L", the input is output, as it is, to Rec (DECK SYNC, pin 5).	6-5
DECK SYNC.	3	Tuner Sel.	1 pulse from the instant the tuner AM or FM key is operated.	When Rec Mute (DECK SYNC, pin 2) is "L", the selector is switched to "Tuner".	6-5
	1	Green	During deck play, including FF search, REW search, 1-program repeat, index scan and DASH & PLAY (except during dubbing).	The moment the signal becomes "H", switches the selector to "Tape" and sets Play/Stop (DECK SYNC, pin 4) to "H". Inhibit (PHONO SYNC, pin 5) is set to "L".	6-2~3
	2	Rec Mute	During deck recording (except during dubbing).	Inhibits the switching of selector.	6-5
	3	Red	During deck recording, ARM, Rec Pause modes (except during dubbing).	Inhibits Air Check (TUNER SYNC, pin 2) and permits Up/Down (PHONO SYNC, pin 3, CD SYNC, pin 2). Inhibit (PHONO SYNC, pin 5) is set to "L".	6-3~5
	8	M-Dubbing	When the deck is in manual dubbing mode.	Forces the recording terminal output switch to ON.	6-6

CIRCUIT DESCRIPTION

CIRCUIT DESCRIPTION

5-2 Output line

Conn.	Pin No.	Name	Condition for turning signal "H"	System operation	Ref. No. on timing chart
PHONO SYNC.	4	Play/Cut	When the selector "PHONO" is lit.	When the turntable tonearm is in the Rest position, auto play starts the moment the signal changes from "L" to "H". When it's not in the Rest position, auto cut takes place the moment there is the change from "H" to "L".	6-2~3
	5	Inhibit	When both Green (DECK SYNC, pin 1) and Red (DECK SYNC, pin 3) are "L".	The turntable accepts the DUBBING key only when the signal is "H".	6-3~4
DECK SYNC.	4	Play/Stop	When the selector "Tape" is lit.	The deck starts playback when the signal changes from "L" to "H". During playback, DPSS, ARM or REC PAUSE, the deck enters stop mode when the signal changes from "H" to "L".	6-2~3
	5	Rec	With the selector set to "Tuner" and Green (DECK SYNC, pin 1) or Red (DECK SYNC, pin 3) "H", when the tuner AIR CHECK key is pressed. 1 pulse is also output a moment after the tonearm is lifted down by operating the turntable DUBBING key while inhibit (PHONO SYNC, pin 5) is "H".	Same operation as when the deck REC key is pressed.	6-4~5
	6	Up/Down	With the selector set to "Phono" and Green (DECK SYNC, pin 1) or Red (DECK SYNC, pin 3) in "H", when the turntable stylus is set down on the record. With the selector set to "CD/Aux"; when the CD player is playing a disc.	Recording starts when the signal changes from "L" to "H" with the deck in ARM or Rec Pause mode. When it changes from "H" to "L" during recording, the deck enters Rec Pause mode after Auto Rec Mute.	6-4

6. OPERATION TIMING DIAGRAM (THE UNIT IS msec UNLESS OTHERWISE SPECIFIED.)

6-1 When power is switched ON/OFF

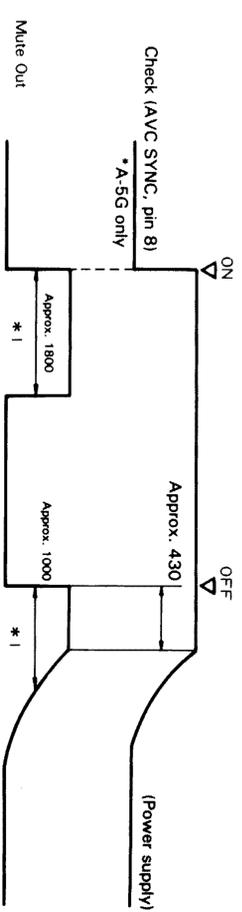

* 1 The timing value when power is switched OFF (OFF) is that of the A-5G

6-2 When, after pressing the amp TAPE key during turntable play, the deck is stopped and then the TAPE key is pressed again:

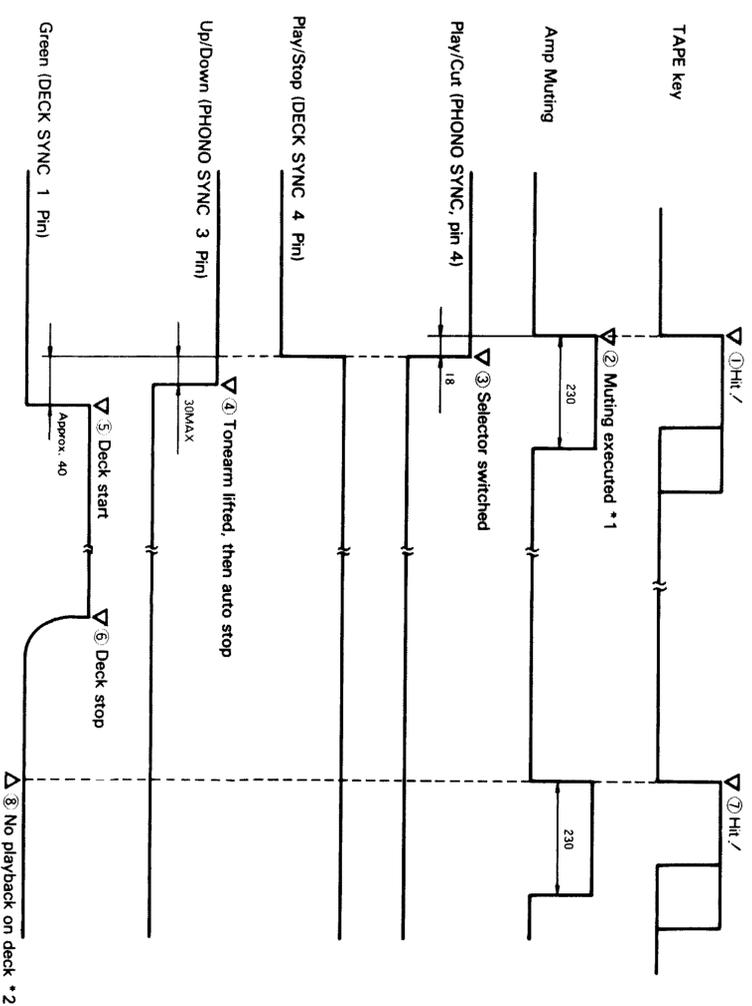

* 1 The amp outputs the Mute Out signal as soon as the selector signal is input and, if the selector signal is still input after approx. 18 ms, switches Play/Cut to "L" and Play/Stop to "H" at the same time. With these two signals, change from "L" to "H" means PLAY and that from "H" to "L" means STOP.

* 2 As the deck starts by change of Play/Stop from "L" to "H", it does not start when the selector has already been set to "TAPE".

CIRCUIT DESCRIPTION

6-3 When the deck PLAY is pressed during recording, then the turntable PLAY is pressed:

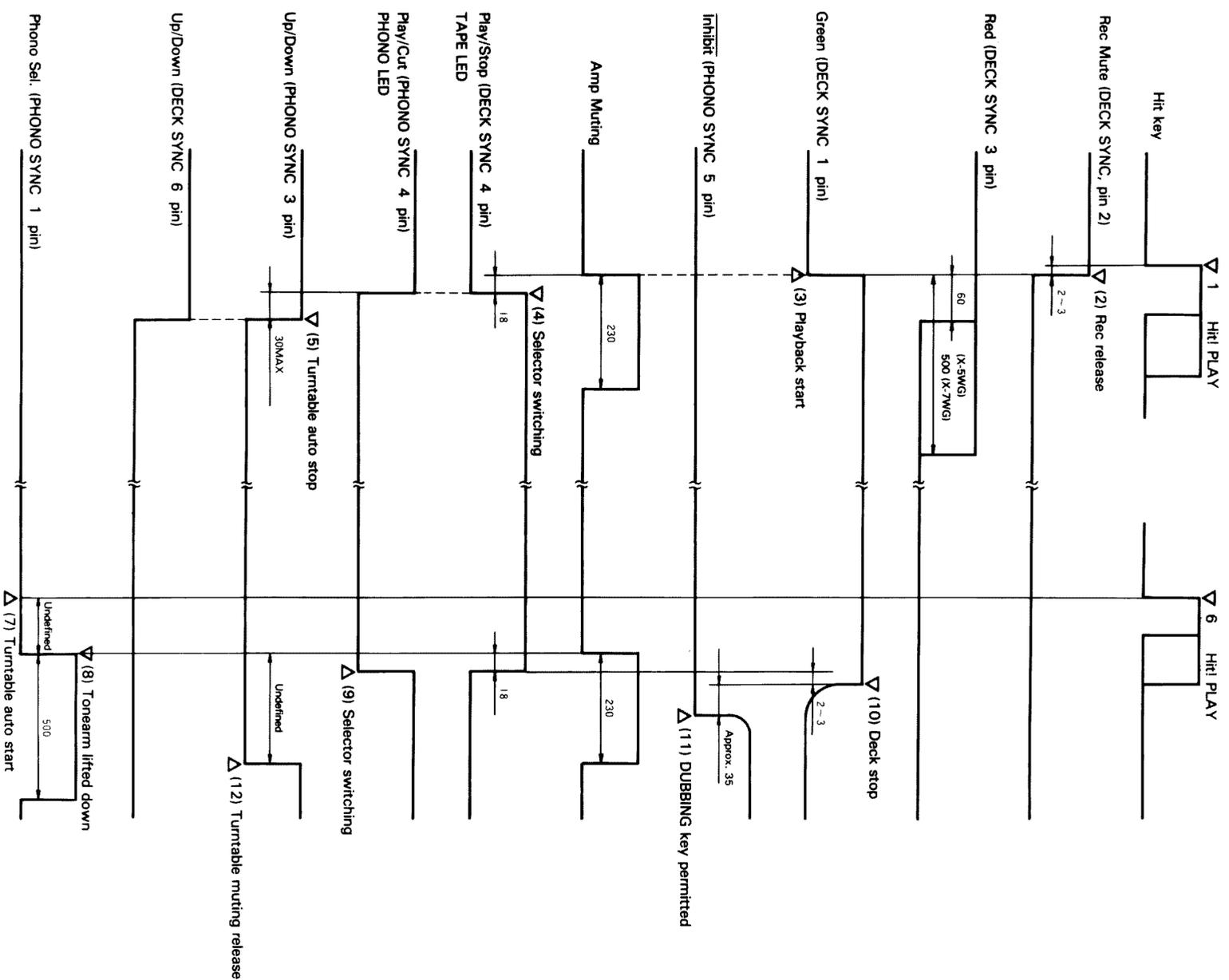

6-4 When the turntable DUBBING key is pressed:

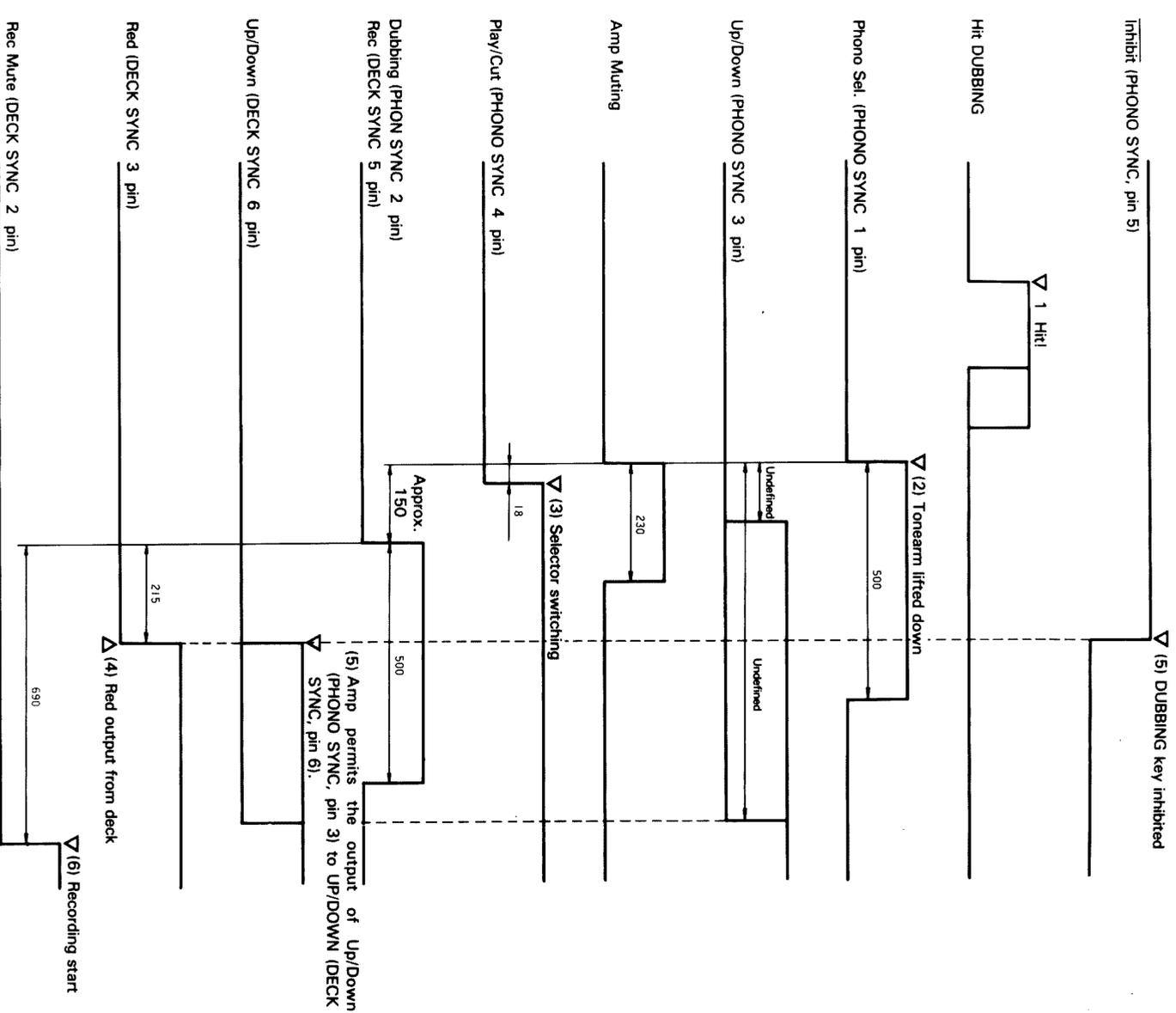

CIRCUIT DESCRIPTION

CIRCUIT DESCRIPTION

6-5 When the tuner FM (or AM) and AIR CHECK keys are simultaneously pressed twice:

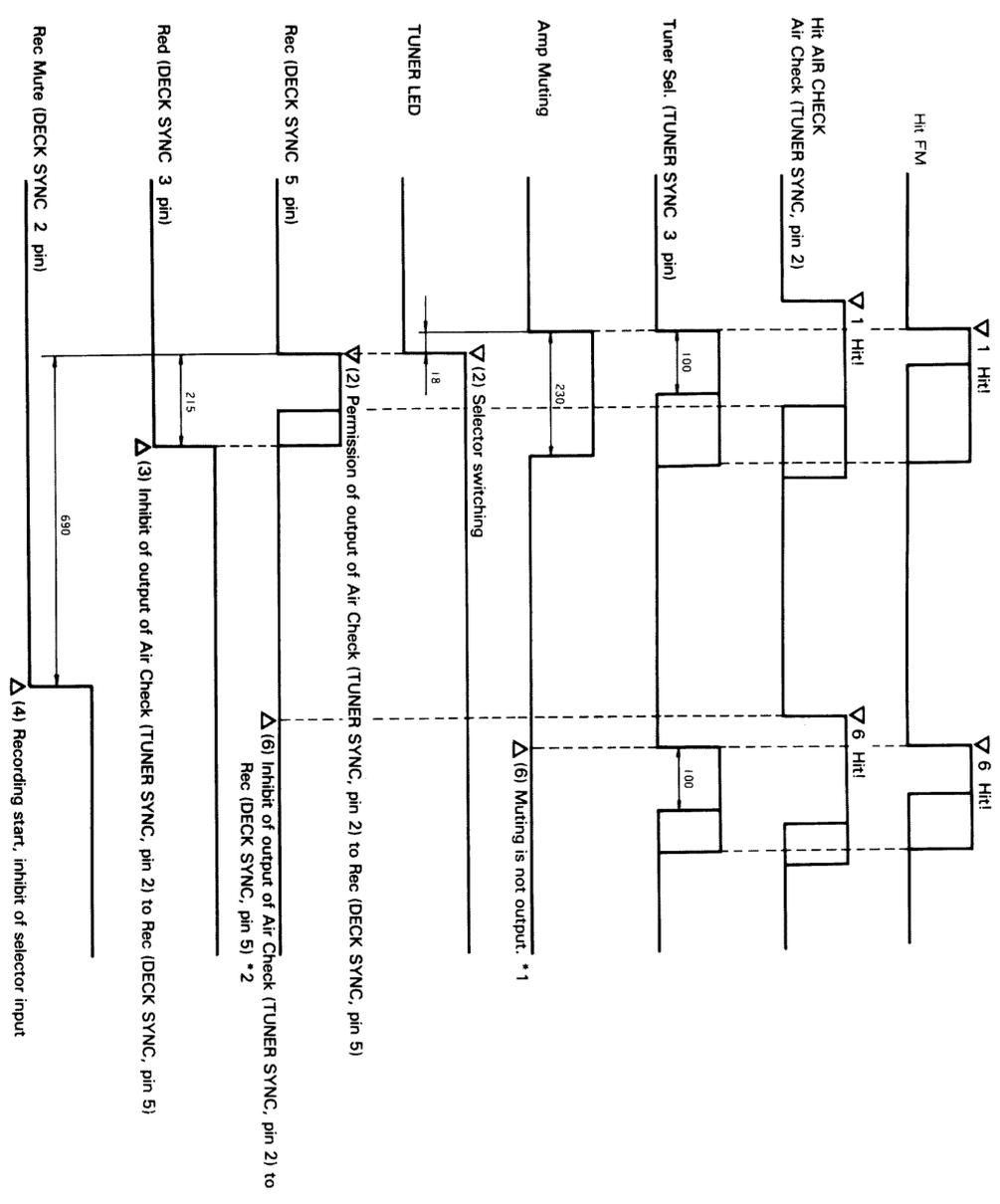

- * 1 When Rec Mute is "H", the amp does not perform switching with any selector signal and Mute Out is not output.
- * 2 When Red (DECK SYNC, pin 3) is "H", Air Check (TUNER SYNC, pin 2) is not output to Rec (DECK SYNC, pin 5) even by pressing the AIR CHECK key.

CIRCUIT DESCRIPTION

6-6 When Deck A PLAY key is pressed, then Deck B REC key is pressed (manual dubbing):

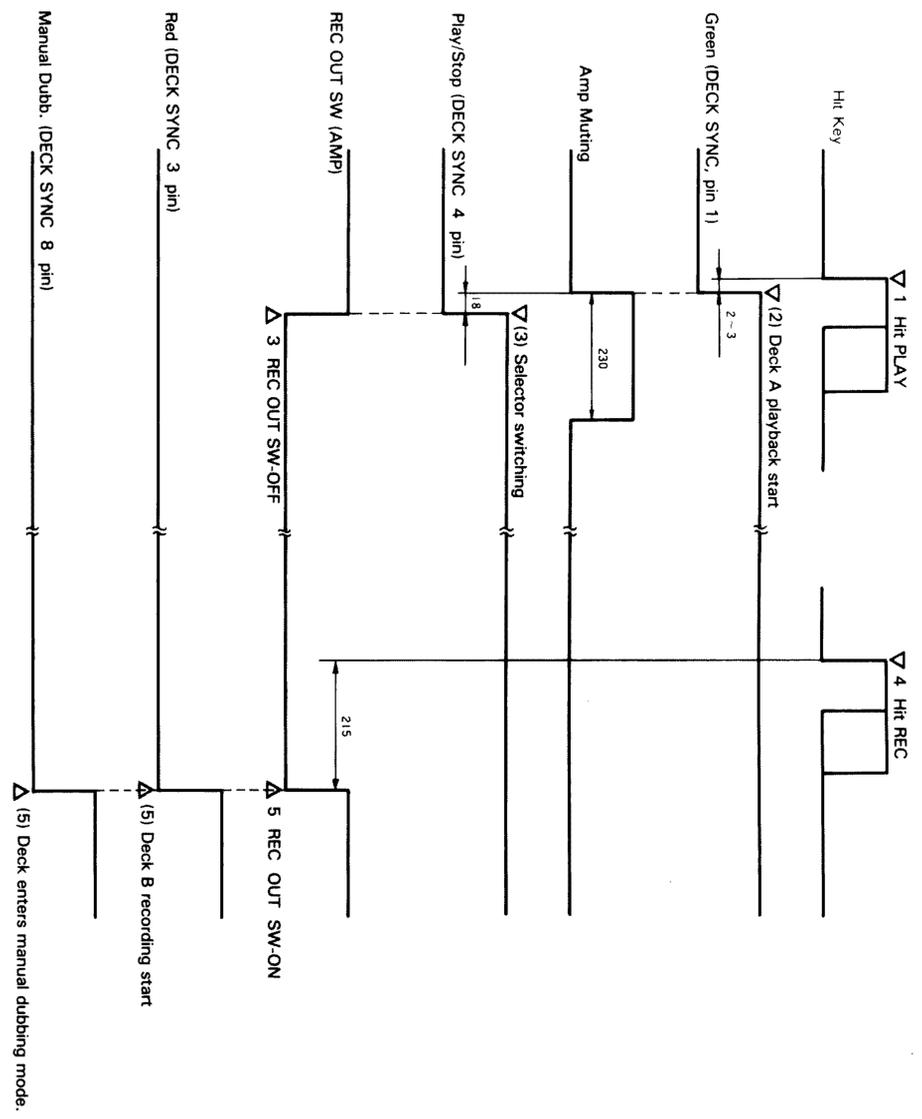

CIRCUIT DESCRIPTION

7-3 Synchro recording circuit

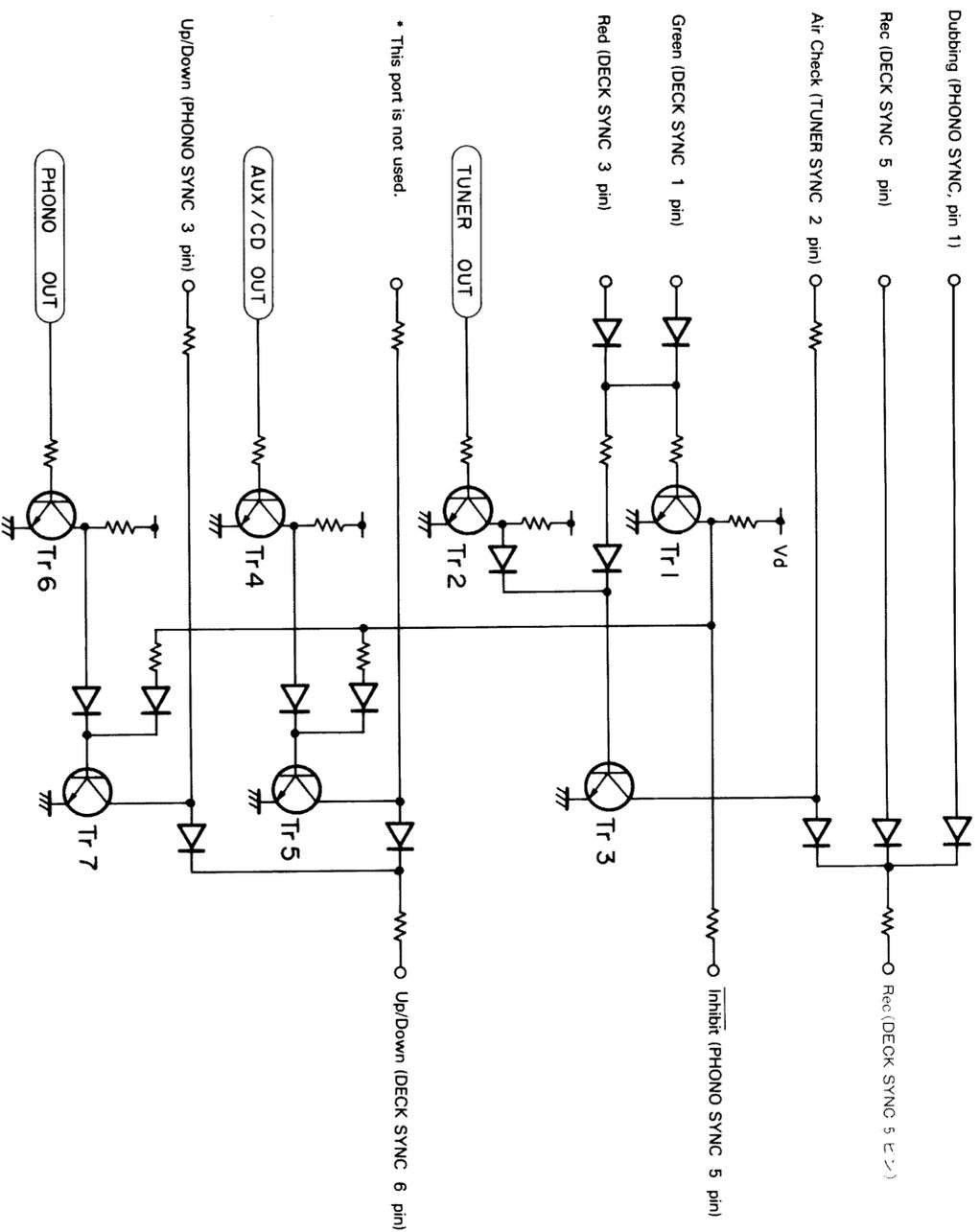

Tr. No.	Operation	Ref. No.	
		A-5G	A-7G
1	ON during deck Play, Rec, Rec Pause and ARM (except normal dubbing mode).	Q38	Q10
2	ON when the selector is in "TUNER" (with the LED lit).	Q27	Q8
3	ON when Tr. 1 or Tr. 2 is ON (to inhibit the Air Check signal).	Q28	Q7
4	ON when the selector is in "AUX/CD" (with the LED lit).	Q30	Q5
5	OFF when both Tr. 1 and Tr. 4 are OFF.	Q29	Q6
6	ON when the selector is in "PHONO" (with the LED lit).	Q32	Q3
7	OFF when both Tr. 1 and Tr. 6 are ON (to permit the Up/Down signal from the turntable).	Q31	Q4

8. FEATURES OF EASY OPERATION SYSTEM (SUMMARY)

- 1) The amp selector is switched by the Select signal from other units as well as by manual operation. However, selector switching is not accepted when the deck is recording in modes other than normal dubbing mode.
- 2) The operation commands from the amp to other units are synchronized with the selector indicator LEDs. The deck/turntable plays when the LED is lit and stops when it goes off. However, these signals are accepted only by the deck and turntable.
- 3) This system is provided with manual dubbing mode: When Deck A is put to play mode and Deck B is then put to record mode, the playback sound of Deck A is output from the amp REC OUT terminal. To make possible recording on Deck B which may be impossible in the ordinary way, the M-Dubb signal (DECK SYNC, pin 8) is output in manual dubbing mode so that, using this signal, the amp forcibly switches ON the REC OUT analog switch.
- 4) For synchro recording, the amp outputs two types of signal to the deck: Rec (DECK SYNC, pin 5) and Up/Down (DECK SYNC, pin 6). The Rec signal, which has the same function as the deck REC key, is output in the form of pulse when the tuner AIR CHECK key or turntable DUBBING key is pressed. So that the AIR CHECK key signal is accepted only when the selector is set to "TUNER" and is not accepted once the deck has entered record mode, the Red signal (DECK SYNC, pin 3) is used for inhibition. The turntable DUBBING key signal, which is not accepted in record mode, is accepted when the amp is outputting the Inhibit signal (PHONO SYNC, pin 5). (The Inhibit signal is also not output when the deck is in play mode.) When the key is pressed, the turntable outputs the Phono Sel. signal (PHONO SYNC, pin 1) to switch the selector to "PHONO", then outputs Dubbing signal (PHONO SYNC, pin 2) to put the deck in record mode.
- 5) On the other hand, if the Up/Down signals, which are output simultaneously and continuously from the turntable, is output to the deck, it would synchronize with both units or start recording from the stop mode. To prevent this, the turntable Up/Down signal (PHONO SYNC, pin 3) is programmed to be output only when the selector is set to "PHONO" and the deck is in Rec, Rec Pause or ARM mode.

A-7G A-7G

9. SYSTEM BLOCK LEVEL DIAGRAM OF SYNCHRONIZED OPERATION FOR ROXY IV

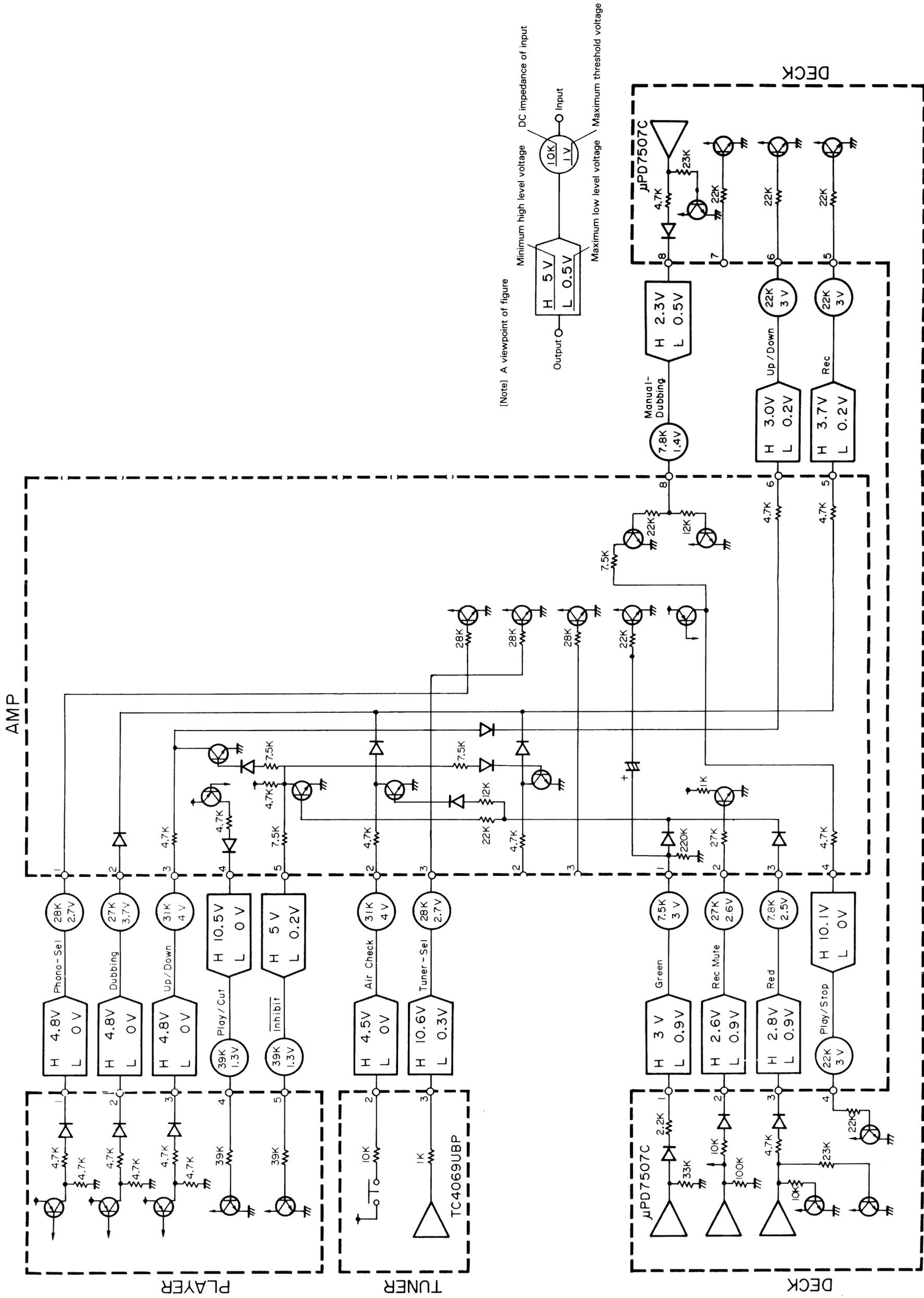

(Note) The constant may be changed in the Figure.

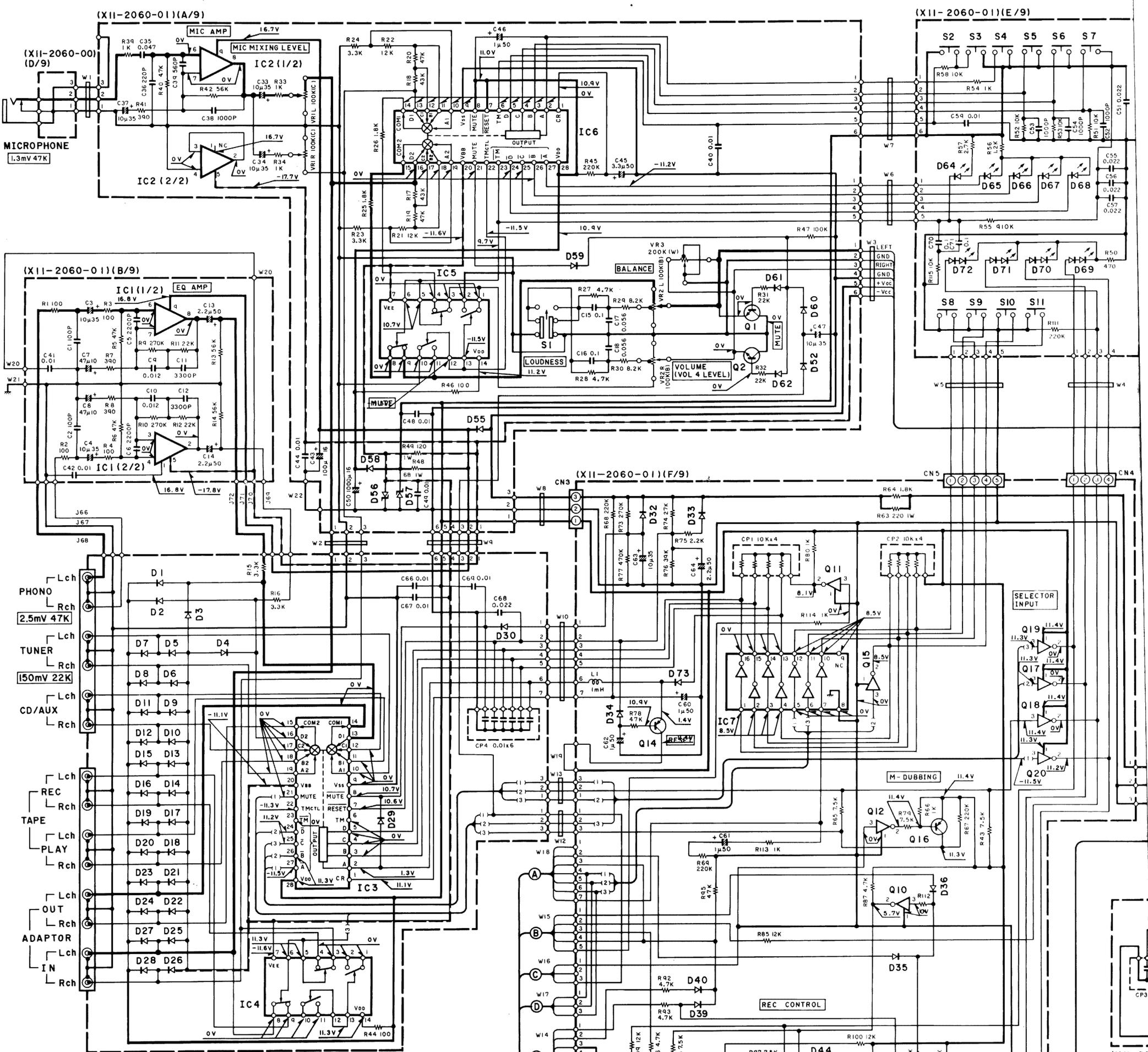

- (XII-2060-01)
- IC 1 : AN6555F
 - IC 2 : AN6555
 - IC 3,6 : LC7815H
 - IC 4,5 : LC4066BH
 - IC 7 : BA6251
- Q1 ~ 8 : 2SC945(A)(Q,P) or 2SC1740S(Q,R)
 - Q10 ~ 12,15 : DTC124EFF
 - Q14,16 : 2SA733(A)(Q,P) or 2SA933S(Q,R)

- (XII-2060-01)
- Q17 ~ 20
 - D1, 3 ~ 28
 - D2, 29, 35, 51
 - D30, 32 ~

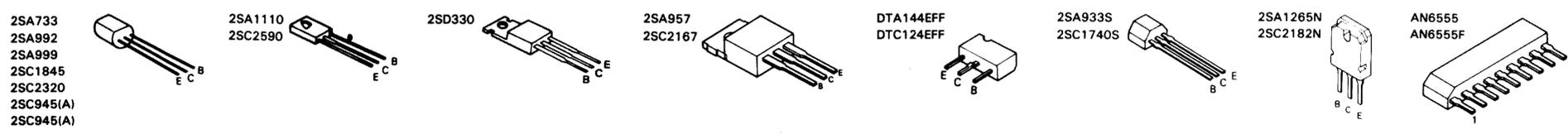

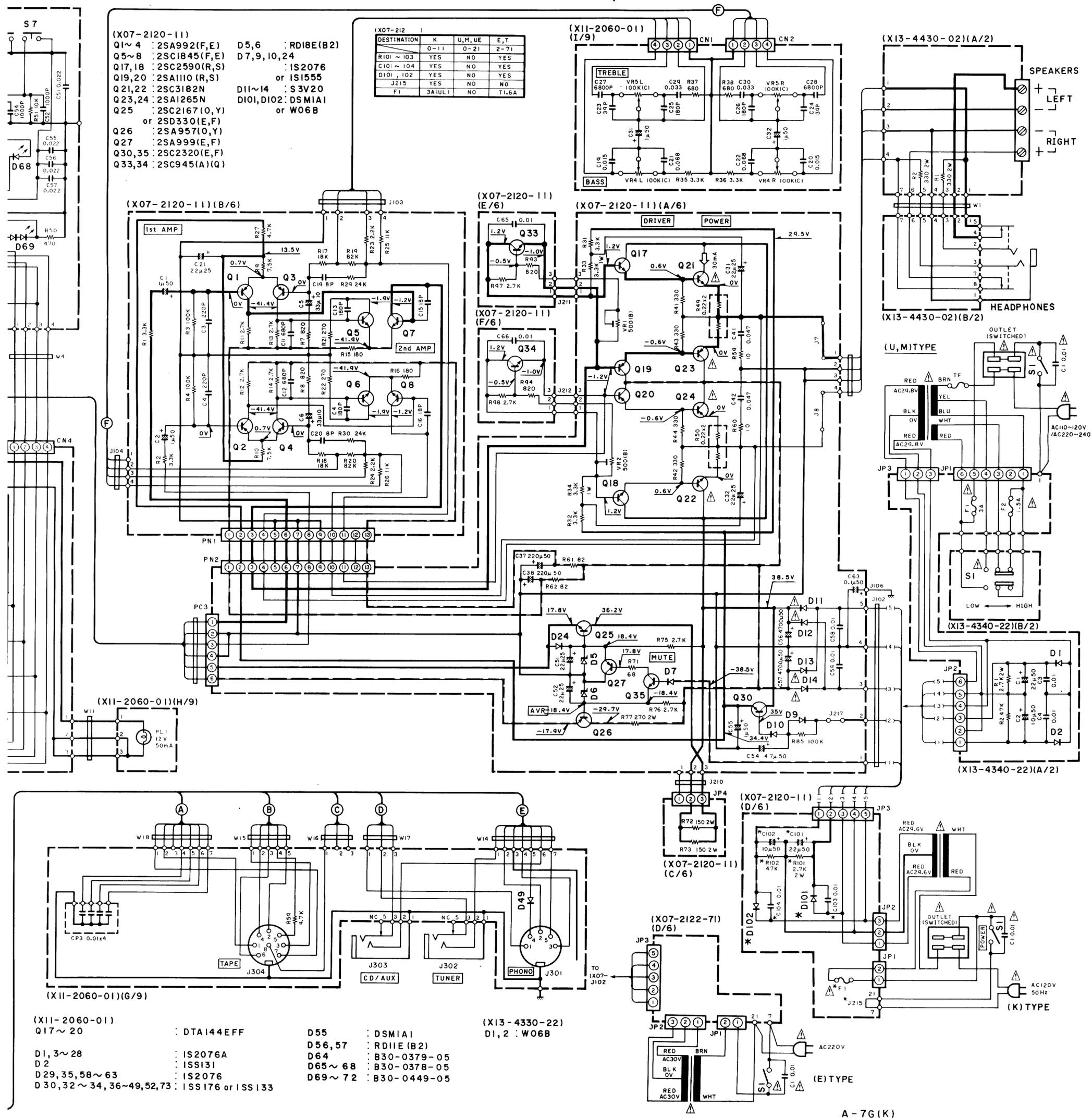

DC voltages are as measured with a high impedance voltmeter with no signal input. Values may vary slightly due to variations between individual instruments or/and units.

Les tensions c.c. doivent être mesurées avec un voltmètre à haute impédance sans signal d'entrée. Les valeurs peuvent différer légèrement du fait des variations inhérentes aux appareils et aux instruments de mesure individuels.

Die angegebenen Gleichspannungswerte wurden mit einem hochohmigen Spannungsmesser ohne Eingangssignal gemessen. Dabei schwanden die Meßwerte aufgrund von Unterschieden zwischen einzelnen Instrumenten oder Geräten u.U. geringfügig.

CAUTION: For continued safety, replace safety critical components only with manufacturer's recommended parts (refer to parts list). Indicates safety critical components. To reduce the risk of electric shock, leakage-current or resistance measurements shall be carried out (exposed parts are acceptably insulated from the supply circuit) before the appliance is returned to the customer.

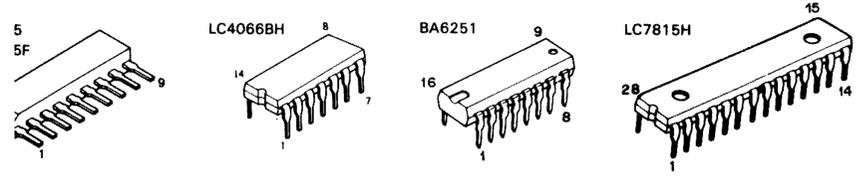

SYSTEM OPERATION LIST TABLE

AMP mode	KEY operation DECK mode	Phono (AMP)	Tuner (AMP) AM, FM (TUNER)	Aux./CD (AMP)	Tape (AMP)	Play/Cut (PLAYER)	Clear/Skip, Numbers key 1 - 7 (PLAYER)	FWD, REV, CUE (PLAYER)	Play, Play & REW, FF & REW, Index Scan (DECK-A) Play, Play & REW, FF & REW (DECK-B)	
PHONO	Stop, Play-Pause, FF, REV, Blank Search (DECK-B), Rec-Standby (DECK-B)	If the turntable tonearm has been lifted down and a record is being played, the amp speaker sound is muted for an instant.	When the turntable tonearm is not on the arm rest, auto cut takes place and the amp selector is switched to TUNER, producing the tuner sound.	When the turntable tonearm is not on the arm rest, auto cut takes place, the amp selector is switched to Aux./CD.	When the turntable tonearm is not on the arm rest, auto cut takes place, the amp selector is switched to TAPE and, if a tape has been loaded in the deck, playback starts (with priority on DECK-B).	When the turntable tonearm is not on the arm rest, auto cut takes place. If the tonearm is on the arm rest, auto play takes place.	The turntable performs the operation selected.	When the turntable tonearm, which has been above the disc and is not on the arm rest, is lifted down by pressing the CUE key, DECK-B enters REC mode if it has been in STOP mode.	When the turntable tonearm is not on the arm rest, auto cut takes place, the amp selector is switched to TAPE and the deck performs the operation selected.	
	Dubbing, Fast-Dubbing	↑	↑	↑	When the turntable tonearm is not on the arm rest, auto cut takes place, the amp selector is switched to TAPE and the sound from DECK-A in DUBBING mode is heard.	↑	↑	The turntable performs the operation selected.	The selector is not switched even by pressing of DECK-A's PLAY key. With other keys, the same operation as above.	
	ARM (DECK-B), Rec-Pause (DECK-B)	↑	↑	The above operation is performed.		When the turntable tonearm is not on the arm rest, auto cut takes place, the amp selector is switched to TAPE and DECK-B starts playback.	Same operation as above. However, in auto play, DECK-B enters REC mode synchronized with the turntable the moment the tonearm is lifted down.	When the turntable has been playing a disc and the tonearm is shifted to the program selected, DECK-B starts to record the moment the tonearm is lifted down.	When the turntable tonearm, which has been above the disc and is not on the arm rest, is lifted down by pressing the CUE key, DECK-B enters REC mode. Other operations are same as above.	When the turntable tonearm is not on the arm rest, auto cut takes place, the amp selector is switched to TAPE and the deck performs the operation selected.
	Rec (DECK-B)	X		X		X		When the turntable tonearm is not on the arm rest, auto cut takes place. If it has been playing a disc, DECK-B enters ARM mode. If the tonearm is on the arm rest, auto play takes place and recording of the disc starts.	When the turntable has been playing a disc and the tonearm is shifted to the program selected, DECK-B enters ARM mode the moment the tonearm is lifted up and enters REC mode when it is lifted down.	If the turntable has been playing a disc, DECK-B enters ARM mode the moment the tonearm is lifted up and enters REC PAUSE mode 4 seconds later.
TUNER	Stop, Play-Pause, FF, Rew, Blank-Search (DECK-B), Rec-Standby (DECK-B)	The amp selector is switched to PHONO and, when the turntable tonearm is on the arm rest, auto play starts.	The amp speaker sound is muted for an instant. No change takes place with the turntable operation even if it's operating.	The amp selector is switched to Aux./CD. No change with the turntable.	The amp selector is switched to TAPE and, if a tape has been loaded in the deck, playback starts (with priority on DECK-B). No change with the turntable.	When the turntable tonearm is not on the arm rest, auto cut takes place. When it is on the arm rest, auto play takes place and the amp selector is switched to PHONO the moment the tonearm is lifted down.	The turntable performs the operation selected and the amp selector is switched to PHONO the moment the tonearm is lifted down.	The amp selector is switched to PHONO the moment the turntable tonearm is lifted down by pressing the CUE key. If the tonearm is up above the disc, the DUBBING key has already been pressed and DECK-B is in STOP mode, it enters REC mode the moment the tonearm is lifted down.	The amp selector is switched to TAPE and the deck performs the operation selected.	
	Dubbing, Fast-Dubbing	↑	↑	↑	The amp selector is switched to TAPE and the sound from DECK-A in DUBBING mode is heard.	↑	↑	When the turntable tonearm is lifted down by pressing the CUE key, the amp selector is switched to PHONO.	The amp selector is not switched even by pressing of DECK-A's PLAY key. With other keys, the same operation as above.	
	ARM (DECK-B), Rec-Pause (DECK-B)	After the above operation, the tonearm is lifted down and DECK-B enters REC mode. When a record is being played, DECK-B enters REC mode the moment the selector is switched.	↑	The above operation is performed.		The above operation is performed, and DECK-B starts playback.	Same operation as above except that, when the selector is switched to PHONO, DECK-B enters REC mode synchronized with the turntable.	Same operation as above but, when the selector is switched to PHONO, DECK-B enters REC mode synchronized with the turntable.	Same operation as above but, when the selector is switched to PHONO, DECK-B enters REC mode synchronized with the turntable.	The amp selector is switched to TAPE and the deck performs the operation selected.
	Rec (DECK-B)	X		X		X		The turntable starts the operation selected but no change takes place with other units.	The turntable performs the operation selected but no change takes place with other units.	The turntable performs the operation selected. No change with other units.
CD/AUX	Stop, Play-Pause, FF, Rew, Blank-Search (DECK-B), Rec-Standby (DECK-B)	The amp selector is switched to PHONO and, when the turntable tonearm is on the arm rest, auto play starts.	The amp selector is switched to TUNER.	The amp selector is switched to AUX/CD.	The amp selector is switched to TAPE and, if a tape has been loaded in the deck, playback starts (with priority on DECK-B). No change with the turntable.	When the turntable tonearm is not on the arm rest, auto cut takes place. When it is on the arm rest, auto play takes place and the amp selector is switched to PHONO the moment the tonearm is lifted down.	The turntable performs the operation selected and the amp selector is switched to PHONO the moment the tonearm is lifted down.	The amp selector is switched to PHONO the moment the turntable tonearm is lifted down by pressing of the CUE key. If the tonearm is above the disc, the DUBBING key has already been pressed and DECK-B is in STOP mode, it enters REC mode the moment the tonearm is lifted down.	↑	
	Dubbing, Fast-Dubbing	↑	↑	↑	The amp selector is switched to TAPE and the sound from DECK-A in DUBBING mode is heard. No change with the turntable.	↑	↑	When the turntable tonearm is lifted down by pressing of the CUE key, the amp selector is switched to PHONO.	No change with the video amp selector even when DECK-B's PLAY key is pressed. With other keys, the same operation as above.	
	ARM (DECK-B), Rec-Pause (DECK-B)	After the above operation, the tonearm is lifted down and DECK-B enters REC mode. When a record is being played, DECK-B enters REC mode the moment the selector is switched.	↑	The above operation is performed.		The amp selector is switched to TAPE and DECK-B starts playback.	Same operation as above except that, when the selector is switched to PHONO, DECK-B enters REC mode synchronized with the turntable.	Same operation as above except that, when the selector is switched to PHONO, DECK-B enters REC mode synchronized with the turntable.	Same operation as above but, when the selector is switched to PHONO, DECK-B enters REC mode synchronized with the turntable.	The amp selector is switched to TAPE and the deck performs the operation selected.
	Rec (DECK-B)	X		X		X		The turntable starts the operation selected but no change takes place with other units.	The turntable performs the operation selected and no change takes place with other units.	The turntable performs the operation selected. No change with other units.
TAPE	Stop, Play-Pause, FF, Rew, Blank-Search (DECK-B), Rec-Standby (DECK-B)	The amp selector is switched to PHONO and, when the turntable tonearm is on the arm rest, auto play starts. When DECK-B is in BS or RS mode, it enters STOP mode.	The amp selector is switched to TUNER and, when DECK-B is in BS or RS mode, it enters STOP mode. No change with other units.	The amp selector is switched to Aux./CD and, if DECK-B is in BS or RS mode, it enters STOP mode. No change with the turntable.	If the sound from a deck has been produced, the amp speaker sound is muted for an instant.	When the turntable tonearm is not on the arm rest, auto cut takes place. When it is on the arm rest, auto play takes place and the amp selector is switched to PHONO the moment the tonearm is lifted down. If DECK-B is in BS or RS mode, it enters STOP mode.	The turntable performs the operation selected and the amp selector is switched to PHONO the moment the tonearm is lifted down. When DECK-B is in BS or RS mode, it enters STOP mode.	When the turntable tonearm is lifted down by pressing of the CUE key, the amp selector is switched to PHONO and DECK-B enters STOP mode if it has been in BS or RS mode. If the tonearm is above the disc, the DUBBING key has already been pressed and DECK-B is in STOP mode, it enters REC mode the moment the tonearm is lifted down.	The deck performs the operation selected. No change with other units.	
	Dubbing, Fast-Dubbing	↑	↑	↑	↑	↑	↑	When the turntable tonearm is lifted down by pressing the CUE key, the amp selector is switched to PHONO.	↑	
	Play (not M-Dubb.), DPSS (DECK-B)	At the same time as the above operation, the deck enters STOP mode. No change with other units.	The amp selector is switched to TUNER and the deck enters STOP mode. No change with other units.	The amp selector is switched to Aux./CD and the deck enters STOP mode. No change with the turntable.	↑	Same operation as above. When the amp selector is switched, the deck enters STOP mode.	Same operation as above. When the amp selector is switched, the deck enters STOP mode.	Same operation as above. When the amp selector is switched, the deck enters STOP mode.	Same operation as above. The deck enters STOP mode the moment the amp selector is switched.	↑
	ARM (DECK-B), Rec-Pause (DECK-B), ARM, Rec-Pause (Manual Dubb.)	↑	↑	↑	↑	↑	↑	↑	↑	↑
	Rec (DECK-B), Rec (Manual Dubb.)	X		X		X		The turntable performs the operation selected but no change takes place with other units.	The turntable performs the operation selected but no change takes place with other units.	The turntable performs the operation selected. No change with other units.

REV. CUE (PLAYER)	Play, Play & REW, FF & REW, Index Scan (DECK-A) Play, Play & REW, FF & REW (DECK-B)	Rec. (DECK-B)	Dubbing (PLAYER)	Air Check (TUNER)
When the turntable tonearm, as been above the disc on the arm rest, is lifted by pressing the CUE key, the DUBBING key, enters REC mode if it has TOP mode.	When the turntable tonearm is not on the arm rest, auto cut takes place, the amp selector is switched to TAPE and the deck performs the operation selected.	When DECK-B is in STOP mode, it enters REC mode synchronized with the turntable.	When the turntable tonearm is on the arm rest, auto play takes place. If DECK-B is in STOP mode at the first arm lift-down after the DUBBING key is pressed, DECK-B enters REC mode.	
The selector is not switched even by pressing of DECK-A's PLAY key. With other keys, the same operation as above.			When the turntable tonearm is on the arm rest, auto play takes place. No change with the decks.	
When the turntable tonearm, as been above the disc on the arm rest, is lifted by pressing the CUE key, enters REC mode. Other are same as above.	When the turntable tonearm is not on the arm rest, auto cut takes place, the amp selector is switched to TAPE and the deck performs the operation selected.	DECK-B enters REC mode.		
When the turntable has been playing a CD, DECK-B enters ARM mode and the tonearm is lifted, enters REC PAUSE mode 4 seconds later.		DECK-B enters ARM mode and, 4 seconds later, REC PAUSE mode.		
When the amp selector is switched to the moment the turntable is lifted down by pressing key. If the tonearm is up on the disc, the DUBBING key has already been pressed and is in STOP mode, it enters STOP mode the moment the arm is lifted down.	The amp selector is switched to TAPE and the deck performs the operation selected.	When DECK-B is in STOP mode, it enters REC mode.	When the turntable tonearm is on the arm rest, auto play takes place. If DECK-B is in STOP mode at the first arm lift-down after the DUBBING key is pressed, the amp selector is switched to PHONO and DECK-B enters REC mode.	When DECK-B is in STOP mode, it starts to record tuner sound.
When the turntable tonearm is down by pressing the CUE key, the amp selector is switched to PHONO.	The amp selector is not switched even by pressing of DECK-A's PLAY key. With other keys, the same operation as above.		When the turntable tonearm is on the arm rest, auto play takes place and the amp selector is switched to PHONO the moment the arm is lifted down. No change with the decks.	
The operation as above but, the selector is switched to DECK-B enters REC mode synchronized with the turntable.	The amp selector is switched to TAPE and the deck performs the operation selected.	DECK-B enters REC mode.		
When the turntable performs the operation. No change with its.		DECK-B enters ARM mode and, 4 seconds later, REC PAUSE mode.		
When the amp selector is switched to the moment the turntable is lifted down by pressing CUE key. If the tonearm is on the disc, the DUBBING key has already been pressed and is in STOP mode, it enters STOP mode the moment the arm is lifted down.		When DECK-B is in STOP mode, it enters REC mode synchronized with the CD player.	When the turntable tonearm is on the arm rest, auto play takes place. If DECK-B is in STOP mode at the first arm lift-down after the DUBBING key is pressed, the amp selector is switched to PHONO and DECK-B enters REC mode.	
When the turntable tonearm is down by pressing of the CUE key, the amp selector is switched to PHONO.	No change with the video amp selector even when DECK-B's PLAY key is pressed. With other keys, the same operation as above.		When the turntable tonearm is on the arm rest, auto play takes place and the amp selector is switched to PHONO the moment the arm is lifted down. No change with the decks.	
The operation as above but, the selector is switched to DECK-B enters REC mode synchronized with the turntable.	The amp selector is switched to TAPE and the deck performs the operation selected.	DECK-B enters REC mode.		
When the turntable performs the operation. No change with its.		DECK-B enters ARM mode and, 4 seconds later, REC PAUSE mode.		
When the turntable tonearm is lifted by pressing of the CUE key, the selector is switched to DECK-B enters STOP mode if it has been in BS or RS mode, the tonearm is above the disc, the DUBBING key has already been pressed and DECK-B is in STOP mode, it enters REC mode the moment the tonearm is lifted down.	The deck performs the operation selected. No change with other units.	When DECK-B is in STOP mode, it enters REC mode but nothing is recorded.	When the turntable tonearm is on the arm rest, auto play takes place. If DECK-B is in STOP, BS or RS mode at the first arm lift-down after the DUBBING key is pressed, the amp selector is switched to PHONO and DECK-B enters REC mode.	
When the turntable tonearm is down by pressing the CUE key, the amp selector is switched to PHONO.				
The operation as above. The selector is switched to STOP mode the moment the amp selector is switched to PHONO.		When DECK-A is in PLAY mode, DECK-B enters REC mode, i.e. manual dubbing starts.	When the turntable tonearm is on the arm rest, the amp selector is switched to PHONO and the deck enters STOP mode.	
		DECK-B enters REC mode.		
		DECK-B enters ARM mode and, 4 seconds later, REC PAUSE mode.		

[How to use the tables]

1. The horizontal axis indicates the switches to be operated and the vertical axis indicates the modes before the switches are operated.
2. With both axes, switches/modes which have the same results are included in the same column wherever possible and the units to which the switches or modes belong are indicated in brackets. Whenever the results are different, separate columns are used.
3. With both axes, switches/modes which have no relationship with the system operation are omitted.
4. Descriptions in the table refer only to the operation related to the system operation and not to the operation of each unit. The modes are not changed unless otherwise specified.
5. In the table, (°) means AND and (,) means OR.
6. Symbols and their meaning



No change in operation



Same operation as above

RS REC standby

BS Blank search

PARTS LIST

* New Parts
Parts without Parts No. are not supplied.
Les articles non mentionnés dans le Parts No. ne sont pas fournis.
Teile ohne Parts No. werden nicht geliefert.

Ref. No. 参照番号	Address 位置	Parts No. 部品番号	Description 部 品 名 / 規 格	Desti- nation 仕 向	Re- marks 備考
A-7G					
1	1B	A01-1380-02	METALLIC CABINET	E	
1	1B	A01-1401-02	METALLIC CABINET	KUMT	
1	1B	A01-1401-02	METALLIC CABINET	UE	
2	2A	A20-4204-02	PANEL	KUME	
2	2A	A20-4204-02	PANEL	UE	
2	2A	A20-4297-02	PANEL	T	
3	2B	A22-0491-03	SUB PANEL ASSY		
4	2A	A53-0646-04	FRONT BOARD ASSY		
8	2A	B03-1594-04	DRESSING PLATE (POWER)		
9	2A	B03-1577-04	DRESSING PLATE (INSIDE OF DOOR)		
10	2A	B03-1578-04	DRESSING PLATE (SELECTOR WINDOW)		
11	2A	B03-1579-04	DRESSING PLATE (SEL INDICATOR)		
12	2A	B07-1253-04	ESCUTCHEON (POWER)		
13	2A	B07-1319-04	ESCUTCHEON (LOUDNESS)		
-	-	B46-0092-03	WARRANTY CARD	K	
-	-	B46-0094-03	WARRANTY CARD	UE	
-	-	B46-0095-03	WARRANTY CARD	UE	
-	-	B46-0122-03	WARRANTY CARD	E	
-	-	B46-0123-03	WARRANTY CARD	T	
-	-	B50-5454-00	INSTRUCTION MANUAL (ENGLISH)	KUME	
-	-	B50-5454-00	INSTRUCTION MANUAL (ENGLISH)	UE	
-	-	B50-5455-00	INSTRUCTION MANUAL (FRENCH)	ME	
-	-	B50-5456-00	INSTRUCTION MANUAL (SPANISH)	M	
-	-	B50-5457-00	INSTRUCTION MANUAL (G.I.D)	E	
-	-	B50-5458-00	INSTRUCTION MANUAL (ARABIC)	M	
-	-	B50-5600-00	INSTRUCTION MANUAL (ENGLISH)	T	
-	-	B58-0222-14	CAUTION CARD (PRESET 220V)	UE	
-	-	B58-0223-04	CAUTION CARD (PRESET 120V)	U	
-	-	B58-0269-04	CAUTION CARD	K	
-	-	B59-0092-00	SERVICE DIRECTORY	UE	
C1	1B	C91-0023-05	CERAMIC 0.01UF AC250V	UMUE	
C1	1B	C91-0647-05	CERAMIC 0.01UF P	KET	
18	1C	E03-0064-05	AC OUTLET	KUMUE	
19	1C	E30-0181-05	AC POWER CORD	K	
19	1C	E30-0459-05	AC POWER CORD	E	
19	1C	E30-0587-15	AC POWER CORD	E	
19	1C	E30-0812-05	AC POWER CORD	UM	
20	1A	E30-0948-05	CORD WITH DIN CONN(SP) T. TABLE		
21	1B	E30-0949-05	CORD WITH PLUG (2P) TUNER		
22	1B	E30-0950-05	CORD WITH DIN CONN (BP) C. DECK		
26	1B	G11-1080-04	SOFT TAPE (ON PWR TRANSFORMER)		
-	-	H01-5334-04	ITEM CARTON CASE	KUME	
-	-	H01-5334-04	ITEM CARTON CASE	UE	
-	-	H01-5388-04	ITEM CARTON CASE	T	
-	-	H10-1715-02	POLYSTYRENE FRAMED FIXTURE		
-	-	H25-0078-04	PROTECTION BAG (235X315)		
-	-	H25-0148-04	PROTECTION BAG (110X230X0.07)		
-	-	H25-0223-04	PROTECTION BAG (750X350)		
30	2B, 2C	J02-0129-05	FOOT		
31	1C	J12-0094-05	PIN (SHORT PIN)		

E: Scandinavia & Europe H: Audio Club K: USA P: Canada

S: South Africa T: England U: PX (Far East, Hawaii)

UE: AA FES (Europe) X: Australia M: Other Areas

△ indicates safety critical components.

PARTS LIST

* New Parts
Parts without Parts No. are not supplied.
Les articles non mentionnés dans le Parts No. ne sont pas fournis.
Teile ohne Parts No. werden nicht geliefert.

Ref. No. 参照番号	Address 位置	Parts No. 部品番号	Description 部 品 名 / 規 格	Desti- nation 仕 向	Re- marks 備考
32	2A	J21-3326-05	JACK MOUNTING HARDWARE		
33	1C	J42-0083-05	POWER CORD BUSHING		
-	-	J61-0307-05	WIRE BAND		
37	1B	K27-0948-04	KNOB (BUTTON) LOUDNESS		
38	2A	K29-1914-04	KNOB ASSY (BUTTON) POWER		
39	2A	K29-1910-04	KNOB BASS, TREB, VOL 4, BAL, MIX		
40	1B	K29-1959-04	KNOB ASSY (BUTTON) DOOR LOCK		
44	1B	L01-3881-05	POWER TRANSFORMER	K	
44	1B	L01-3882-05	POWER TRANSFORMER	E	
44	1B	L01-3885-05	POWER TRANSFORMER	UE	
44	1B	L01-3887-05	POWER TRANSFORMER	T	
48	1C	N08-0128-35	BINDING POST (GND)		
52	1B	S40-0009-05	PUSH SWITCH (DOOR LOCK)		
51	1B	S40-1066-05	PUSH SWITCH (POWER TYPE)		
POWER AMPLIFIER UNIT (X07-2120-11)					
C1, 2	-	CE04FW1H010M	ELECTRO 1.0UF 50MV		
C3, 4	-	CC45FSL1H221J	CERAMIC 220PF J		
C5, 6, 7	-	CE04FW1A330M	ELECTRO 33UF 10MV		
C11, 12	-	CK45FB1H681K	CERAMIC 680PF K		
C13, 14	-	CC45FSL1H181J	CERAMIC 180PF J		
C15, 16	-	CC45FSL1H180J	CERAMIC 18PF J		
C19, 20	-	CC45FSL1H080D	CERAMIC 8.0PF D		
C21, 32	-	CE04FW1E220M	ELECTRO 22UF 25MV		
C31, 32	-	CE04FW1E220M	ELECTRO 22UF 25MV		
C37, 38	-	CE04FW1H221M	ELECTRO 220UF 50MV		
C41, 42	-	CF92FV1H473J	MF 0.047UF J		
C51, 52	-	CE04FW1E220M	ELECTRO 22UF 25MV		
C54	-	CE04FW1H470M	ELECTRO 47UF 50MV		
C55	-	CE04FW1H010M	ELECTRO 1.0UF 50MV		
C56, 57	-	C90-0580-05	ELECTRO 4700UF 50MV		
C58, 59	-	CK45E2H103P	CERAMIC 0.010UF P		
C63	-	CE04FW1H0R1M	ELECTRO 0.1UF 50MV		
C65, 66	-	CF92FV1H103J	MF 0.010UF J		
C101	-	CE04FW1H220M	ELECTRO 22UF 50MV		KET
C102	-	CE04FW1H100M	ELECTRO 10UF 50MV		KET
C103, 104	-	CK45FR2H103K	CERAMIC 0.010UF K		KET
F1	1C	F05-1623-05	FUSE (SEMKO) T1.6A		ET
F1	1C	F06-3023-05	FUSE (UL) 3A		K
56	1C	J13-0041-05	FUSE CLIP		K
56	1C	J13-0055-05	FUSE CLIP		ET
K	1B, 1C	N09-0333-05	TAPPING SCREW (Ø3X12) PWR TR		
R15, 16	-	RD14AB2E181J	FL-PROOF RD 180 J 1/4W		
R21, 22	-	RD14GB2E271J	FL-PROOF RD 270 J 1/4W		
R31, 34	-	RS14GB3A332J	FL-PROOF RS 3.3K J 1W		
R41	-	RD14AB2E331J	FL-PROOF RD 330 J 1/4W		
R42	-	RD14GB2E331J	FL-PROOF RD 330 J 1/4W		
R43, 44	-	RD14AB2E331J	FL-PROOF RD 330 J 1/4W		
R49, 50	-	R90-0187-05	MULTI-COMP 0.22X2 K 5W		
R59, 60	-	RS14GB3D100J	FL-PROOF RS 10 J 2W		
R61, 62	-	RD14AB2E820J	FL-PROOF RD 82 J 1/4W		
R72, 73	-	RS14GB3D151J	FL-PROOF RS 150 J 2W		

E: Scandinavia & Europe H: Audio Club K: USA P: Canada

S: South Africa T: England U: PX (Far East, Hawaii)

UE: AA FES (Europe) X: Australia M: Other Areas

△ indicates safety critical components.

PARTS LIST

* New Parts
Parts without Parts No. are not supplied.
Les articles non mentionnés dans le Parts No. ne sont pas fournis.
Teile ohne Parts No. werden nicht geliefert.

Ref. No. 参照番号	Address 位置	Parts No. 部品番号	Description 部品名/規格	Desti- nation 向	Re- marks 備考
R75, 76		RS14GB3A272J	FL-PROOF RS 2.7K J 1W		
R77		RS14GB3D271J	FL-PROOF RS 270 J 2W	KET	
R101		RS14GB3D272J	FL-PROOF RS 2.7K J 2W		
VR1, 2		R12-0306-05	TRIMMING PNT. (500) IDLE		
D5, 6		RD18E(B2)	ZENER DIODE		
D7		1S1555	DIODE		
D7		1S2076	DIODE		
D9, 10		1S1555	DIODE		
D9, 10		1S2076	DIODE		
D11 -14		S3V20	DIODE		
D24		1S1555	DIODE		
D24		1S2076	DIODE		
D101, 102		DSM1A1	DIODE	KET	
D101, 102		W06B	DIODE	KET	
Q1 -4		2SA992(F,E)	TRANSISTOR		
Q5 -8		2SC1845(F,E)	TRANSISTOR		
Q17, 18		2SC2590(R,S)	TRANSISTOR		
Q19, 20		2SA1110(R,S)	TRANSISTOR		
Q21, 22		2SC3182N	TRANSISTOR		
Q23, 24		2SA1265N	TRANSISTOR		
Q25		2SC2167(O,Y)	TRANSISTOR		
Q25		2SC330(E,F)	TRANSISTOR		
Q26		2SA957(O,Y)	TRANSISTOR		
Q27		2SA999(E,F)	TRANSISTOR		
Q30		2SC2320(E,F)	TRANSISTOR		
Q33, 34		2SC945(A)	TRANSISTOR		
Q35		2SC2320(E,F)	TRANSISTOR		
CONTROL UNIT (X11-2060-01)					
D64	2B	B30-0379-05	LED (SLP-151B-50) MUTING		
D65 -68	2B	B30-0378-05	LED (SLP-251B-50) 1,2,3,4		
D69 -72	2B	B30-0449-05	LED (SLP-206B) SELECTOR		
PL1	2A	B30-1015-05	LAMP (12V 0.05A) 8P IND		
C1, 2		CC45FSL1H101J	CERAMIC 100PF J 35WV		
C3, 4		CE04FW1V100M	ELECTRO 10UF J 50MV		
C5, 6		CK45FB1H222K	CERAMIC 2200PF K 10MV		
C7, 8		CE04FW1A470M	ELECTRO 47UF J 50MV		
C9, 10		CF92FV1H123J	MF 0.012UF J		
C11, 12		CF92FV1H332J	MF 3300PF J		
C13, 14		CE04FW1H2R2M	ELECTRO 2.2UF J 50MV		
C15, 16		CF92FV1H104J	MF 0.10UF J		
C17, 18		CF92FV1H563J	MF 0.056UF J		
C19, 20		CF92FV1H153J	MF 0.015UF J		
C21, 22		CF92FV1H683J	MF 0.068UF J		
C23, 24		CC45FSL1H390J	CERAMIC 39PF J		
C25, 26		CC45FSL1H181J	CERAMIC 180PF J		
C27, 28		CF92FV1H682J	MF 6800PF J		
C29, 30		CF92FV1H333J	MF 0.033UF J		
C31, 32		CE04FW1H010M	ELECTRO 1.0UF J 50MV		
C33, 34		CE04FW1V100M	ELECTRO 10UF J 35WV		
C35		CF92FV1H473J	MF 0.047UF J		
C36		CC45FSL1H221J	CERAMIC 220PF J		
C37		CE04FW1V100M	ELECTRO 10UF J 35WV		
C38		CK45FB1H102K	CERAMIC 1000PF K		
C39		CK45FB1H561K	CERAMIC 560PF K		

E: Scandinavia & Europe H: Audio Club K: USA
S: South Africa T: England U: PX(Far East, Hawaii)
UE: AAFES(Europe) X: Australia M: Other Areas

△ indicates safety critical components.

PARTS LIST

* New Parts
Parts without Parts No. are not supplied.
Les articles non mentionnés dans le Parts No. ne sont pas fournis.
Teile ohne Parts No. werden nicht geliefert.

Ref. No. 参照番号	Address 位置	Parts No. 部品番号	Description 部品名/規格	Desti- nation 向	Re- marks 備考
C40		CK45FF1H103Z	CERAMIC 0.010UF Z		
C41		C91-0083-05	CERAMIC 0.01UF Z		
C42		CK45FF1H103Z	CERAMIC 0.010UF Z		
C43		CE04FW1C101M	ELECTRO 100UF 16WV		
C44		CK45FF1H103Z	CERAMIC 0.010UF Z		
C45		CE04FW1H3R3M	ELECTRO 3.3UF 50MV		
C46		CE04FW1H010M	ELECTRO 1.0UF 50MV		
C47		CE04FW1V100M	ELECTRO 10UF 35WV		
C48		CK45FF1H103Z	CERAMIC 0.010UF Z		
C49		C91-0083-05	CERAMIC 0.01UF N		
C50		C90-1256-05	ELECTRO 1000UF 16WV		
C51		C91-0085-05	CERAMIC 0.022UF N		
C52 -54		CK14B1H102K	CERAMIC 1000PF N		
C55 -57		C91-0085-05	CERAMIC 0.022UF N		
C59		C91-0083-05	CERAMIC 0.01UF N		
C60		CE04FW1H010M	ELECTRO 1.0UF 50MV		
C61		CE04FW1H010M	ELECTRO 1.0UF 50MV		
C62		CE04W1H010M	ELECTRO 1.0UF 50MV		
C63		CE04FW1V100M	ELECTRO 10UF 35WV		
C64		CE04FW1H2R2M	ELECTRO 2.2UF 50MV		
C66, 67		C91-0083-05	CERAMIC 0.01UF N		
C68		CK45FF1H223Z	CERAMIC 0.022UF Z		
C69		C91-0083-05	CERAMIC 0.01UF N		
C70, 71		CF92FV1H104J	MF 0.10UF J		
66	2B	E11-0141-05	PHONE JACK (2P) MIC MIX		
68	1C	E13-0624-05	PHONE JACK (6P) INPUT		
69	1C	E13-0818-05	PHONE JACK (8P) TAPE ADAPTOR		
J301	1C	E06-0519-05	CYL RECEPTACLE (5P) TUNABLE		
J302, 303	1C	E11-0152-05	MINI JACK (3P) TUNER, CD PLAYER		
J304	1C	E06-0806-05	CYL RECEPTACLE (8P) C-DECK		
-		J61-0307-05	WIRE BAND		
L1		L40-1021-12	SMALL FIXED INDUCTOR (1.0MH,K)		
DP1, 2		R90-0233-05	MULTI-COMP 10KX4 J 1/6W		
CP3		R90-0188-05	MULTI-COMP 0.01UF X4		
CP4		R90-0241-05	MULTI-COMP 10000UF X7		
R48		RS14KR3D820J	FL-PROOF RS 82 J 2W		
R49		RS14KR3D121J	FL-PROOF RS 120 J 2W		
R63	1B	RS14KR3A221J	FL-PROOF RS 220 J 1W		
VR1	1B	R06-5121-05	POTENTIOMETER(100KX2) MIX LEVEL		
VR2	1B	R06-5119-05	POTENTIOMETER(100KX2) VOLUME		
VR3	1B	R01-5048-05	POTENTIOMETER(200K) BALANCE		
VR4, 5	1B	R06-5120-05	POTENTIOMETER(100KX2) BASS, TREB		
S1	1B	S40-2323-05	PUSH SWITCH (LOUDNESS)		
S2 -11	2B	S40-1085-05	PUSH SW(MUTING, VOL1-4) SELECTOR		
D1		1S2076A	DIODE		
D2		1S5131	DIODE		
D3 -28		1S2076A	DIODE		
D29		1S2076	DIODE		
D30		GMA01-FY1	DIODE		
D32 -34		1S5133	DIODE		
D32 -34		1S5176	DIODE		
D35		1S2076	DIODE		

E: Scandinavia & Europe H: Audio Club K: USA
S: South Africa T: England U: PX(Far East, Hawaii)
UE: AAFES(Europe) X: Australia M: Other Areas

△ indicates safety critical components.

PARTS LIST

* New Parts
Parts without Parts No. are not supplied.
Les articles non mentionnés dans le Parts No. ne sont pas fournis.
Teile ohne Parts No. werden nicht geliefert.

Ref. No. 参照番号	Address 位置	New Parts 新部品	Parts No. 部品番号	Description 部品名/規格	Desti- nation 向備考	Re- marks 備考
D36 -46			1S5133	DIODE		
D36 -46			1S5176	DIODE		
D49			1S5133	DIODE		
D49			1S5176	DIODE		
D52			1S5133	DIODE		
D52			1S5176	DIODE		
D55			DSM1A1	DIODE		
D56 .57			RD11E(B2)	ZENER DIODE		
D58 -62			1S2076	DIODE		
D73			1S5133	DIODE		
D73			1S5176	DIODE		
IC1			AN6555F	IC(OP AMP) X2		
IC2			AN6555	IC(OP AMP) X2		
IC3			LC7815H	IC(4CH SELECTOR)		
IC4 .5			LC4066BH	IC(4CH ANALOG SWITCH)		
IC6			LC7815H	IC(4CH SELECTOR)		
IC7			BAG251	IC(7CH TRANSISTOR ARRAY)		
Q1 -8			2SC1740S(Q,R)	TRANSISTOR		
Q1 -8			2SC945(A)(Q,P)	TRANSISTOR		
Q10 -12			DTC124EFF	DIGITAL TRANSISTOR		
Q14			2SA733(A)(Q,P)	TRANSISTOR		
Q14		*	2SA933S(Q,R)	TRANSISTOR		
Q15			DTC124EFF	DIGITAL TRANSISTOR		
Q16			2SA733(A)(Q,P)	TRANSISTOR		
Q16		*	2SA933S(Q,R)	TRANSISTOR		
Q17 -20			DTA144EFF	DIGITAL TRANSISTOR		
SUB CIRCUIT UNIT (X13-4340-22)						
C1			CE04FW1H220M	ELECTRO	UM	
C2			CE04FW1H100M	ELECTRO	UM	
C3 .4			CK45F1H103Z	CERAMIC	UM	
F1			F05-3022-05	FUSE	UM	
F2			F05-1521-05	FUSE	UM	
72			J13-0041-05	FUSE CLIP	UM	
R1		*	RS14KR30272J	FL-PROOF RS 2.7K J 2W	UM	
S1			S31-2083-05	SLIDE SWITCH (POWER TYPE)	UM	
D1 .2			W06B	DIODE	UM	
SUB CIRCUIT UNIT (X13-4430-02)						
75	1B		E11-0153-05	PHONE JACK (3P) HEADPHONE		
76	1C	*	E20-0455-05	TERMINAL BOARD(4P) SPEAKER		
R1 .2		*	RS14KR30331J	FL-PROOF RS 330 J 2W		

SPECIFICATIONS

Power Amplifier Section

Power Output
40 watts * per channel minimum RMS, both channels driven at 8 ohms from 30 Hz to 20,000 Hz with no more than 0.06% total harmonic distortion

Both Channels Driven into
8 ohms at 1 kHz 45 W +45 W (Except USA, Europe and U.K.)

Total Harmonic Distortion
(30 Hz to 20,000 Hz)
AUX Input to SPEAKER
output 0.06% at rated power

into 8 ohms
0.04% at 1/2 rated power
into 8 ohms

Intermodulation Distortion
(60 Hz:7 kHz = 4:1) 0.02% at rated power
into 8 ohms

Damping Factor 30, at 50 Hz
into 8 ohms

Frequency Response
Overall (AUX - SPEAKER) 10 Hz to 50 kHz, ±3 dB
Input Sensitivity/Impedance
Phono MM 2.5 mV/47 k ohms

Tuner, CD/AUX, Tape 150 mV/22 k ohms

Signal-to-Noise Ratio (HF-A)
Phono MM 73 dB for 2.5 mV input
Tuner, CD/AUX, Tape 100 dB

Maximum Input Level for Phono

MM 120 mV (RMS), at 1 kHz

Output Level/Impedance

Tape REC (Pin) 150 mV/3.3 ohms

Frequency Response for Phono RIAA standard curve ±0.4 dB
(20 Hz to 20,000 Hz)

Tone Control

Bass ±9 dB at 100 Hz

Treble ±9 dB at 10 kHz

Loudness Control

(at -30 dB VOLUME Level) 8 dB at 100 Hz

General

Power Consumption 140 W (USA and Canada:UL and CSA)

180 W (U.K., European coun-tries)

180 W (Others)

AC Outlets Switched 2

(Except U.K., European countries)

Dimensions W: 340 mm (13-3/18")

H: 83.5 mm (3-1/4")

D: 354 mm (13-15/16")

Weight (Net) 6.2 kg (13.6 lb)

* Measured pursuant to Federal Trade Commission's Trade Regulation rule on Power Output Claims for Amplifier in U.S.A.

Kenwood follows a policy of continuous advancements in development. For this reason specifications may be changed without notice.

Kenwood poursuit une politique de progrès constants en ce qui concerne le développement. Pour cette raison, les spécifications sont sujettes à modifications sans préavis.

Kenwood strebt ständige Verbesserungen in der Entwicklung an. Daher bleiben Änderungen der technischen Daten jederzeit vorbehalten.

E: Scandinavia & Europe H:Audio Club K:USA P: Canada

S: South Africa T: England U: FX(Far East, Hawaii)

UE: AAFES(Europe) X: Australia M: Other Areas

△ indicates safety critical components.

ADJUSTMENT/REGLAGES/ABGLEICH

ADJUSTMENT

No.	ITEM	INPUT SETTINGS	OUTPUT SETTINGS	AMPLIFIER SETTINGS	ALIGNMENT POINTS	ALIGN FOR	FIG.
1	IDLE CURRENT	—	Connect a DC voltmeter across R49 (L) R50 (R).	SPEAKER: OFF VOLUME: 0	VR1 (L) VR2 (R)	7mV	(a)

REGLAGES

N°	ITEM	REGLAGE DE L'ENTREE	REGLAGE DE LA SORTIE	REGLAGE DE L'AMPLIFICATEUR	POINTS L'ALIGNEMENT	ALIGNER POUR	FIG.
1	COURANT DE POLARISATION	—	Connecter un voltmètre CC sur R49 (C) R50 (D).	SPEAKER: OFF VOLUME: 0	VR1 (C) VR2 (D)	7mV	(a)

ABGLEICH

NR.	GEGENSTAND	EINGANGS-EINSTELLUNG	AUSGANGS-EINSTELLUNG	VORSTÄRKER EINSTELLUNG	ABGLEICH-PUNKTE	ABGLEICHEN FÜR	ABB.
1	LEERLAUFSTROM	—	Einen Gleichspannungsmesser über R49 (L) R50 (R) anschließen.	SPEAKER: OFF VOLUME: 0	VR1 (L) VR2 (R)	7mV	(a)

EXPLODED VIEW

